

# ROBS4CROPS

## D3.1 Autonomous Capabilites Definition

[rops4crops.eu](https://www.rops4crops.eu)



This project has received funding from the European Union's Horizon 2020 research and innovation programme under grant agreement No 101016807

### D3.1 Autonomous capabilities definition

<b>Author(s)/Organisation(s)</b>	Ferran Roure, Juan Francisco Rascón / EUT
<b>Contributor(s)</b>	AGC, AGI
<b>Work Package</b>	WP3
<b>Delivery Date (DoA)</b>	31 December 2021
<b>Actual Delivery Date</b>	24 December 2021
<b>Abstract:</b>	Definition of autonomous capabilities that the vehicles should have to successfully work in the LSP

Document Revision History			
Date	Version	Author/Contributor/ Reviewer	Summary of main changes
01/12/2021	1	Ferran Roure (EUT)	Document Cretation
07/12/2021	2	Suzanne Baron (AGC)	Add AGC information
07/12/2021	3	Alea Scovill (AGI)	Add AGI information
17/12/2021	4	Fran Rascón (EUT)	Add EUT information
17/12/2021	5	Ferran Roure (EUT)	Review document

Dissemination Level		
PU	Public	Yes
PP	Restricted to other programme participants (including the EC Services)	No
RE	Restricted to a group specified by the consortium (including the EC Services)	No
CO	Confidential, only for members of the consortium (including the EC)	No

### D3.1 Autonomous capabilities definition

ROBS4CROPS Consortium			
Participant Number	Participant organisation name	Short name	Country
1	STICHTING WAGENINGEN RESEARCH	WR	NL
2	GIROPOMA COSTA BRAVA SL	GIR	ES
3	AGROTIKOS SYNETAIRISMOS POLISEOS XIRON KAI NOPON STAFYLION KIATOY KORINTHIAS PIGASOS	PEG	GR
4	SERRATER SL	SER	ES
5	SMART AGRI TECHNOLOGY BV	SAT	NL
6	TERRENA SOCIETE COOPERATIVE AGRICOLE	TER	FR
7	ABEMEC BV	ABE	NL
8	AGREENCULTURE	AGC	FR
9	AGRO INTELLIGENCE APS	AI	DK
10	FOODSCALE HUB ENTREPRENEURSHIP ANDINNOVATION ASSOCIATION	FSH	SR
11	TEYME TECHNOLOGIE AGRICOLA SL	TEY	ES
12	GEPONIKO PANEPISTIMION ATHINON	AUA	GR
13	FUNDACIO EURECAT	EUT	ES
14	KOBENHAVNS UNIVERSITET	UCHP	DK
15	UNIVERSITAET HOHENHEIM	UHOH	DE
16	PANEPISTIMIO PATRON	LMS	GR

#### LEGAL NOTICE

The information and views set out in this application form are those of the author(s) and do not necessarily reflect the official opinion of the European Union. Neither the European Union institutions and bodies nor any person acting on their behalf may be held responsible for the use which may be made of the information contained therein.

Funding Scheme: Innovation Action (IA) • Topic: H2020-ICT-46-2020

Start date of project: 01 January, 2021 • Duration: 48 months

© Robs4Crops Consortium, 2021.

Reproduction is authorised provided the source is acknowledged.

## Table of Content

<b>CHAPTER 1 INTRODUCTION .....</b>	<b>6</b>
<b>CHAPTER 2 VEHICLE DESCRIPTIONS .....</b>	<b>6</b>
CEOL.....	6
ROBOTTI.....	10
RETROFITTED TRACTOR .....	14
<b>CHAPTER 3 LARGE SCALE PILOT DEFINITION AND CONSTRAINTS .....</b>	<b>20</b>
FRANCE: MECHANICAL WEEDING IN VINEYARDS .....	20
FRANCE: MECHANICAL WEEDING IN VEGETABLES .....	20
GREECE: SPRAYING IN TABLE GRAPES .....	21
SPAIN: SPRAYING IN APPLE ORCHARDS .....	22
THE NETHERLANDS: WEEDING IN POTATO-BASED CROP ROTATION .....	22
<b>CHAPTER 4 LARGE-SCALE PILOTS' AUTONOMOUS CAPABILITIES DEFINITION .....</b>	<b>24</b>
CEOL (WEEDING IN FRANCE, IN GREECE) .....	24
ROBOTTI (WEEDING IN NETHERLANDS).....	26
RETROFITTED TRACTOR (SPRAYING IN SPAIN AND GREECE).....	28

## List of tables

Table 1. CEOL's technical characteristics. ....	7
Table 2. Technical characteristics for the Robotti platform. ....	12
Table 3. Sensors on board the Robotti platform. ....	12
Table 4. Technical characteristics for the New Holland T4.F100 tractor. ....	15
Table 5. Characteristics for the vineyard large scale pilot in France. ....	20
Table 6. Characteristics for the vegetable large scale pilot in France. ....	21
Table 7. Characteristics for the large scale pilot in Greece. ....	21
Table 8. Characteristics for the large scale pilot in apple orchards in Spain. ....	22
Table 9. Characteristics for the large scale pilot in potatoes in Nederland. ....	23
Table 10. Safety and navigation characteristics of the Robotti platform. ....	27

## List of figures

Figure 1. Carob robot from AGC. ....	7
Figure 2. Ceol robot from AGC. ....	7
Figure 3. Geofencing perimeter. ....	8
Figure 4. Depth image showing distances to a tree. ....	9
Figure 5. AGC processing pipeline. ....	9
Figure 6. Robotti autonomous platform. ....	10
Figure 7. Dimensiones for the Robotti platform. ....	11
Figure 8. Robotti operator standing in front of the Robotti while the Robotti is stopped. ....	12
Figure 9. Tractor New Holland T4.100F. ....	14
Figure 10. T4.F100 Tractor's dimensions. ....	14
Figure 11. EUT_PC communicates with the retrofitted tractor through the AGCBox. ....	15
Figure 12. Communication architecture between the EUT_PC and the AGCBox. ....	16
Figure 13. Weidmuller access point /client and external antenna. ....	16
Figure 14. Left, Wired e-stop. Centre, remote industrial-grade remote controller. Right, wireless e-stop. ....	17
Figure 15. Pressure-sensitive bumper. ....	18
Figure 16. Sick LMS511 for outdoor safety applications. ....	18
Figure 17. Octree representation of a map. ....	19
Figure 18. Three-point for the CEOL robot. ....	24
Figure 19. Bulb U-turn for the CEOL robot. ....	25
Figure 20. Turning radius for the retrofitted tractor T4.F100. ....	29
Figure 21. Example of sharper turning radius when performing a trajectory due to the SuperSteer technology from New Holland. ....	29
Figure 22. New Holland T4.F100 tractor navigating in different environments with diverse load conditions and presenting distinct slopes. ....	30

### D3.1 Autonomous capabilities definition

List of Abbreviations and Acronyms	
AGC	AGreenCulture
AGI	AgroIntelli
EUT	Eurecat
FC	Farming Controller
IMU	Inertial Measurement Unit
LSP	Large Scale Pilot
ASIL	Automotive Safety Integrity Level

# Chapter 1 Introduction

An important aspect for the success of this project is to demonstrate that autonomous vehicles are able to deal with real-world problems in the day-by-day agricultural life. Robs4Crops wants to show that autonomous robots are a feasible option for the farmers and, in combination with smart implements and a high-level controller, work at least at the same level of an experienced driver.

Demonstrating robust, safe, and efficient autonomous vehicles is the main goal of the WP3. To maximize the impact of the project, three different vehicles will be used, each one with different characteristics that should cover the main use cases in European agriculture. These vehicles will be tested in different Large-Scale Pilots (LSP) where each one will face with different challenges according to the terrain and crop situation.

In this document, the autonomous capabilities needed to meet the demanding project challenges are defined.

# Chapter 2 Vehicle descriptions

In this section, the vehicles used in Robs4Crops are described. Three different vehicles (two robots and a tractor) are available for the large-scale pilots, in combination with different implements in order to prove the feasibility of the autonomous robotics technology for agricultural works.

## CEOL

CEOL is an autonomous robot developed by AGC. It is mainly used in vineyards and exists in a second version that is higher and is usually used in vegetable farming and orchards. The UGV operates autonomously, without interruption or human assistance, leading operations as mechanical weeding. The hybrid powered (diesel/electric) engine gives an autonomy of up to 48 hours. It reduces human hours for repetitive tasks as mechanical weeding. Equipped with tracks, CEOL can operate easily and frequently, with low soil compaction and avoiding soil ruts. CEOL is equipped with a category 1 electric lift (three-point linkage) allowing it to be used with standard farm implements. It can transport or tow a range of implements of different sizes and thus robotize a large part of the work done today with tractors.

CEOL is equipped with an AGC Box giving it a connectivity through WiFi, LoRa<sup>1</sup> and 4G. The 'Safe-fencing' option gives CEOL the capacity to optimise its path and the headland U-Turns without trespassing a predefined contour. As data is cloud-based, the user can download the robot's mission and run it through the application. A mission can be paused and resumed through the application or the remote control. All the emergency stops should be resumed by the user at a proximity of the robot. The navigation is based on a precise positioning of GNSS-RTK and the path is optimised and corrected constantly through the IMU and the RTK corrections from the fixed base.

---

<sup>1</sup> LoRa is a wireless technology that offers **long range**, low power and secure data transmission for M2M and IoT applications. LoRa is based on chirp spread spectrum modulation, which has low power characteristics like FSK modulation but can be used for long range communications. LoRa can be used to connect sensors, gateways, machines, devices, animals, people etc. wirelessly to the cloud.

### D3.1 Autonomous capabilities definition

#### Vehicle dimensions

AGC manufactures two models of the robot:

- **CAROB**: A modular platform with an adjustable width from 1.3 m to 1.6 m and a total height of 1.6 m from the ground.

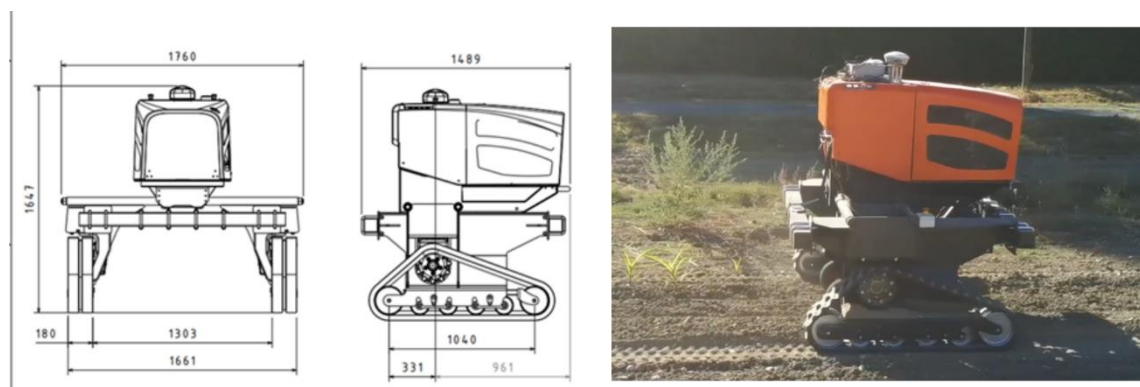

Figure 1. Carob robot from AGC.

- **CEOL** : A fixed-size platform, based on the previous one, with a weight of 750 Kg and a lifting capacity of 300 Kg.

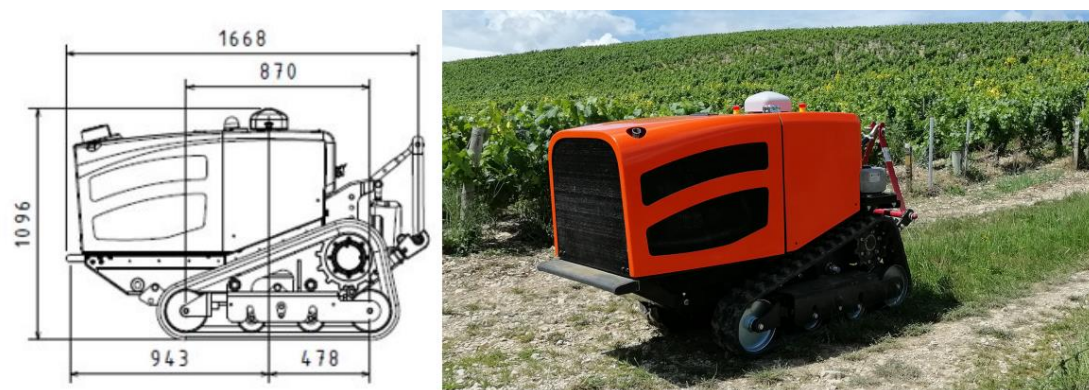

Figure 2. Ceol robot from AGC.

#### Technical characteristics of CEOL

Frame length	170 cm
Adjustable Width	From 72 to 120 cm
Ground clearance	21 cm (16 cm with added weights)
Track width	180 mm
Ground pressure	< 260 g/cm <sup>2</sup>
Tool lift amplitude	25 cm
Lifting capacity	300 kg
Energy thermal autonomy	> 20h
Traction power	10 kW
Propulsion Electric in	48 V
Battery autonomy	60 to 90 minutes
Guiding and positioning	Geo positioning GNSS RTK/NRTK (centimetric precision +/- 2cm)
Remote control range	100 meters
Maximum speed	6 km/hr

Table 1. CEOL's technical characteristics.



## D3.1 Autonomous capabilities definition

### Sensors

#### *Security Safety sensors*

CEOL is equipped with several safety sensors:

- Bumper on the front and on the implements.
- An obstacle detection sensor on the front ensures speed reduction and stopping.
- The “Geo-fencing” technique is a digital security technique for the perimeter of the robotized plot of land.
- Emergency stop buttons.
- Remote control.
- GNSS-RTK.
- Fixed base for GNSS-RTK.
- Working lights package is an option on the CEOL robot.



*Figure 3. Geofencing perimeter.*

#### *Vehicle pose and positioning*

The AGC Box is mounted on the CEOL robot and serves as a GNSS-RTK fixed base and positioning and navigation system. The robot's trajectory can be followed on the application or through a web interface. CEOL has an IMU to improve pose estimation.

CEOL uses a GNSS-RTK and a GNSS base station with internally developed algorithms for the RTK corrections.

### D3.1 Autonomous capabilities definition

#### Environment Perception

The cameras are optional and under development on the CEOL robot. Based on stereo cameras the front and the side of the robot is observed for detection of humans and for plant analysis. An RGB camera is also set on the robot.

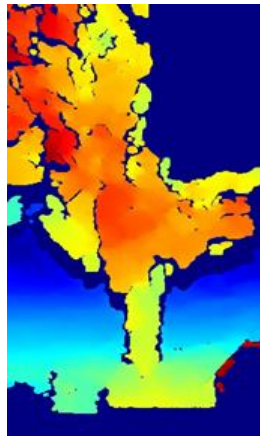

Figure 4. Depth image showing distances to a tree.

#### Communications

CEOL using the AGC Box uses the WiFi, LoRa and 4G according to the connectivity in the chosen plot. A SIM card is used for mobile data connectivity. The operational data collected is stored on the hardware and it can be sent automatically to the application or web interface.

### Localization and Navigation

For the guidance of the UGV several steps are considered:

- Land surveying: defining the perimeter and the crops on the field. The land surveying determines the zones for the mission (when and where to U-turn? Where are the crops situated? High precision and the correct position should be confirmed at the beginning of the row).
- GNSS RTK Asil-B<sup>2</sup> positioning is used for the centimetric precision and an IMU (inertial measurement unit). Internal algorithms were developed for the centimetric



Figure 5. AGC processing pipeline.

precision and corrections.

- Guidance: path planning and U-turns and delivering guiding orders according to the expected field mission.

Control: for the low-level control loops of the speed of the tracks on the right and on the left in accordance with the guiding orders.

---

<sup>2</sup> The automotive safety integrity level (ASIL), defined in the ISO 26262 standard on functional safety, specifies which of the standard's requirements and safety measures apply to each element of the vehicle's electrical and electronic systems, with ASIL-A the least and ASIL-D the most stringent level.

# ROBOTTI

## Hardware description

ROBOTTI is an autonomous implement carrier, automating tasks in agriculture and horticulture. Diesel-powered with a three-point hitch, it can be fitted with standard farm implements to perform different field tasks throughout the season. The working width is up to 3 meters. ROBOTTI weighs around 3.000 kg, minimizing the risk of soil compaction in favour of yields. It works autonomously, which significantly saves man-hours. ROBOTTI has an option of "zero-turn" manoeuvre – which means that it spins around a stationary point, enabling it to turn in narrow headlands, increasing the utilization of the field. It is especially an advantage in bed systems where headlands are usually not farmed.



*Figure 6. Robotti autonomous platform.*

ROBOTTI has a 4G SIM card and is constantly connected to the internet. It is autonomously controlled by a computer that makes optimized route planning according to the user's inputs. All data is cloud-based and the robot downloads and uploads information during work. The robot navigates precise with RTK-GPS technology that has an accuracy of +/- 2 cm, as known from tractors. Furthermore, the user is able to follow ROBOTTI's physical position and status about the task via the webpage.

## D3.1 Autonomous capabilities definition

### Vehicle dimensions

The width of the Robotti is made to order, based on the farmer's crops and plant and bed rows.

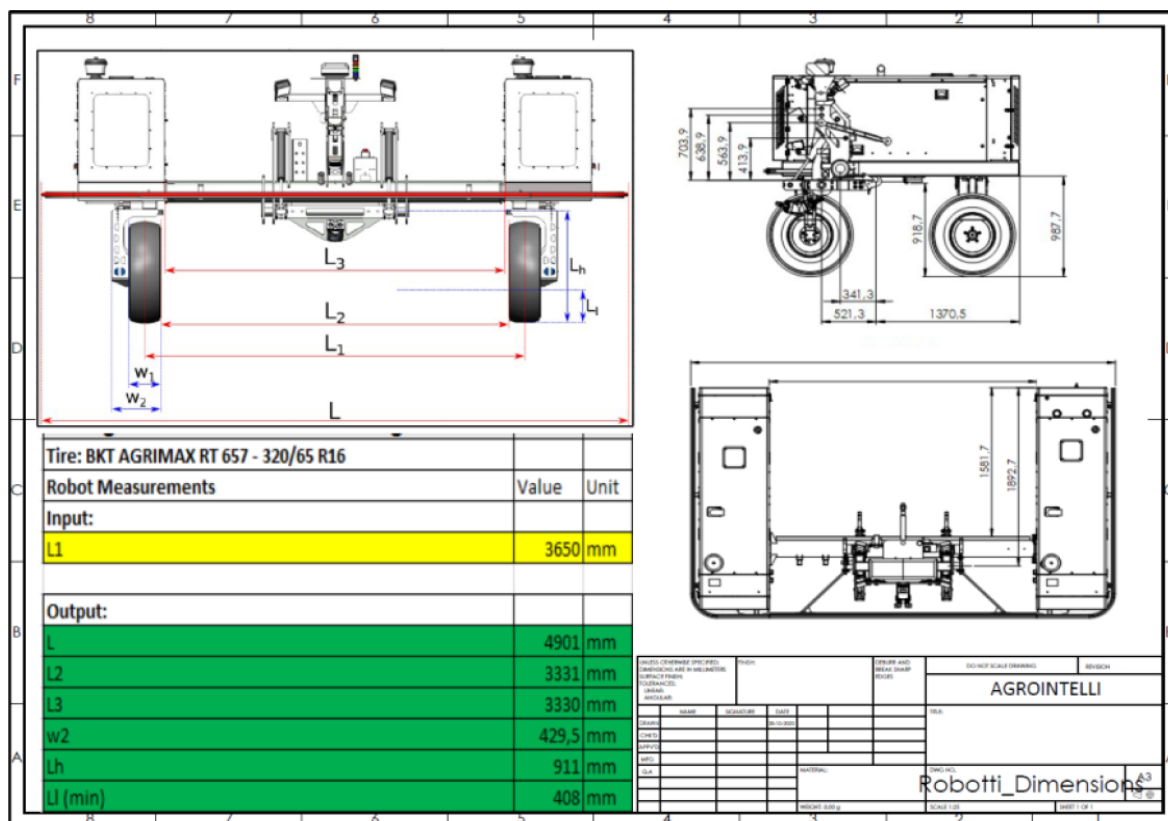

Figure 7. Dimensiones for the Robotti platform.

### Technical characteristics

ROBOTTI model	150D
<b>ENGINE</b>	
Manufacturer	Kubota, diesel
Number of engines	2
Engine model	V2607-CR-TIE5
Cylinders per engine	4
Total engine (s) gross power (kW/hp)	106/144
Battery voltage	12V
Environmental standard	EPA/CARB Tier4 + EU Stage V
<b>TRANSMISSION SYSTEM</b>	
Forward speed in autonomous mode	Up to 8 km/h (5 mph)
High speed (manual)	Up to 10 km/h (6.2 mph)
Low speed (manual)	Up to 5 km/h (3.1 mph)
<b>HYDRAULIC SYSTEM</b>	
Heavy duty PTO motor (20 KW 540 RPM / 40 KW 1000 RPM)	Standard
One double acting proportional outlet (flow) 8 L/miN	Optional

### D3.1 Autonomous capabilities definition

Two double acting and one proportional outlet (flow) 8 L/min	Optional
ADDITIONAL SPECIFICATIONS	
Lift capacity of the three-point hitch	750 kg in the lift linkage
Approximately weight (tons)	3.1
Drive system	4-wheel drive
Steering	2-wheel steering / zereturn

*Table 2. Technical characteristics for the Robotti platform.*

### Sensors

SAFETY AND NAVIGATION	
Pressure sensitive bumper	Standard
Emergency stop buttons	Standard
GNSS-based virtual fencing	Standard
Remote controller /joystick standard	Standard
Laser scanner	Standard
RTK-GNSS (GPS)	Standard
Vision computer and camera package (front and rear)	Optional
Light package (front and rear)	Optional
PlantCam package (4x downward cameras)	Optional

*Table 3. Sensors on board the Robotti platform.*

#### Vehicle pose and positioning

Robotti uses a dual antenna for the RTK GNSS, Hemisphere Vector V500 GNSS. This allows Robotti to know the trajectory of the robot and also the elevation. In addition, Robotti has an IMU that can recognize its tilt.

#### Environment Perception

Currently, a front and rear camera are optional. The front and rear cameras have a fish eye lens to see a wider angle. With the front and rear cameras, it is possible to supervise the operation remotely and verify the safety of the robot.



*Figure 8. Robotti operator standing in front of the Robotti while the Robotti is stopped.*

Currently there are no obstacle detection Deep Learning algorithms available for the front and rear cameras, however at some point in the future, they will be made available.

### D3.1 Autonomous capabilities definition

Four downward facing plant cameras can also be optionally installed on the Robotti. These cameras will be used to identify and analyze the farmer's crop. However, this is still in development and is expected to be released in the future.

Robotti is also installed (standard) with a lidar 3D scanner which will slow and stop the robot if there is an obstacle that comes in front of the robot.

#### *Communications*

Robotti uses a mobile connection and data sim card to communicate to Robotti Web Services. Robotti can also communicate by WiFi.

Robotti records and stores online some of the operational data automatically. However, it is also possible to record all Robotti data using a SSD hard drive.

#### Localization and Navigation

AGI's general strategy for navigation is to match the farmer's needs and expectations as much as possible.

Robotti's navigation planner has many features, allowing the farmer to be able to customize their plans as much as possible to their needs. Currently, Robotti is able to import AB lines, draw ABs, or choose the optimized best path. Then based on these inputs, the paths are automatically created for the farmer.

After the plans are created online, the farmer will have the plans available on the robot. The farmer can select the plan and start it.

## Retrofitted tractor

In order to enhance the applicability of the robotics technology in the real agricultural world, a big handicap should be taken into account: farmers already have machinery to work in fields and replacing all of them with autonomous robots is a very expensive and difficult challenge. Giving them the opportunity to re-use the existing machinery adding a layer of smartness and autonomy it's a good opportunity to speed up the implementation and acceptance of robotics technology in real-life agriculture.

### Hardware description

For this project a small-sized tractor has been selected because the Large Scale Pilots where they have to work require a small vehicle. Concretely, the tractors selected are the **New Holland T4.100F** for the Spanish LSP and the **New Holland T4.80N** for the Greek LSP. As all regular tractors, these vehicle follow the Ackerman configuration (2 front directional front wheels, and 2 non-directional back wheels).



Figure 9. Tractor New Holland T4.100F.

### Vehicle dimentions



Figure 10. T4.F100 Tractor's dimensions.

### Technical characteristics

Ref.	Description	Value (mm)
A	Wheelbase	2435
B	Overall length	3936
C	Minimum overall width	1380
D	Height to top of cab (minimum)	2290
D	Minimum height to rear ROPS <sup>3</sup>	1350

<sup>3</sup> ROPS is the tractor without cabin (Greek LSP), with a foldable structure for protection.

### D3.1 Autonomous capabilities definition

E	Height at centre rear axle to top of cab	1775
F	Ground clearance (maximum)	320
G	Front wheel track setting 4WD	1190/1492
G	Rear wheel track setting 4WD	1130/1530
G	No. of cylinders / Capacity / Valves / Emissions Level	4 / 3400 / 2 / Tier 4A/Stage 3B 4
G	Tank capacity	99 L.
G	Power	99 cv
	Max. Torque ISO TR14396	407@1500rpm

*Table 4. Technical characteristics for the New Holland T4.F100 tractor.*

### Control

The control of the tractor will be divided in two actors. The high level control, based on ROS (planners, trajectories, etc...) will be developed by EUT, running in a dedicated PC mounted on the tractor. The drive-by-wire functionalities will be developed by AGC. The management of these functionalities such as the low level control (wheel movement, steering wheel control) will be carried out by the AGCBox, which will directly communicate with the actuators and encoders of the vehicles to send low level control commands and receive the feedback information from them.

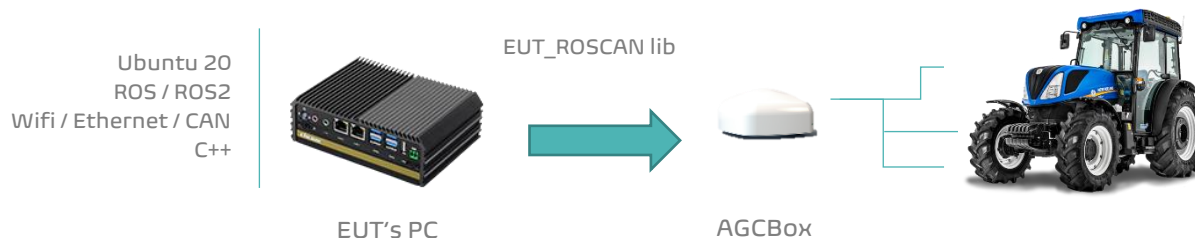

*Figure 11. EUT\_PC communicates with the retrofitted tractor through the AGCBox.*

### Communications

The communication between EUT's PC and AGCBox will be done through CAN connection, using CANOpen libraries and a specifically-built ROS wrapper that codifies ROS messages to CAN messages and vice-versa.



### D3.1 Autonomous capabilities definition

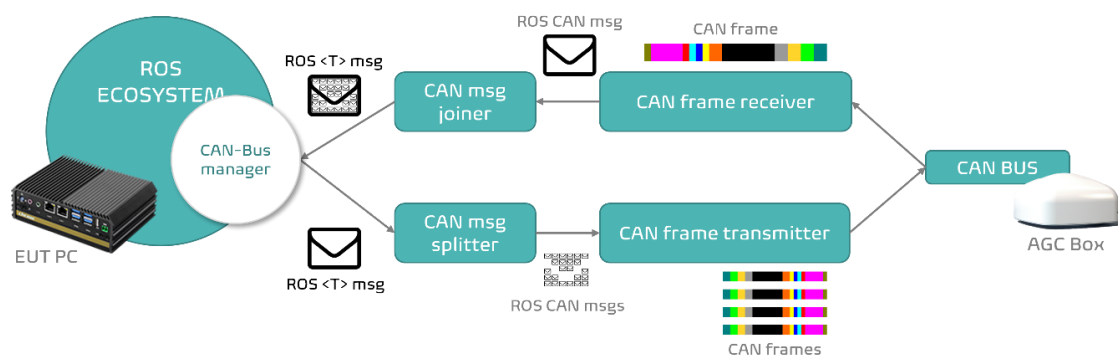

Figure 12. Communication architecture between the EUT\_PC and the AGCBox.

In a first stage of joined development AGC and EUT agreed to exchange the following data in the following directions:

AGCBox => EUT\_PC: IMU data, GNSS ENU data.

EUT\_PC => AGCBox: Control commands (linear velocity, steering angle)

In further development stages more messages of both ecosystems must be agreed to be exchanged between the AGCBox and the EUT\_PC to control the retrofitted tractor for the navigation.

Finally, we will describe the communication with the Farming Controller. As mentioned before, the Farming Controller is being developed by partner LMS and it is fully integrated in the ROS ecosystem, which makes the integration between the EUT's ROS nodes and the farming controller smooth.

EUT\_PC will communicate the farming controller using a network connection (Wifi, 4G, or VPN), since the machine running the farming controller will not be on board the retrofitted tractor, as it is management machine that must be located in a static placement where a user can interact with it to manage the vehicle. Since the communication channel is a network, we rely on the well-known TCP/IP stack that ROS uses internally for its inter-communications-process capabilities.

In order to address the wireless communications to/from the retrofitted tractor, we have selected an industrial Access Point / Client, model IE-WL-AP-BR-CL-ABG-EU by Weidmuller. The device is capable of creating an access point for one or more computers to access the retrofitted tractor. To improve the range of the communications, we have selected an



Figure 13. Weidmuller access point/client and external antenna.

### D3.1 Autonomous capabilities definition

external industrial antenna as well, omnidirectional, with a 6dBi gain. Both the device and antenna are shown in Figure 13.

#### Sensors<sup>4</sup>

An essential part of any autonomous vehicle is the capacity of analyse the environment. For this purpose, different kind of sensors should be mounted during the retrofitting works to be able to obtain all needed information of the scenario, to provide robustness and safety to the vehicle.

##### *Vehicle pose and positioning*

To determine the position and orientation of the tractor three different sensors will be used. GNSS, Inertial (IMU) and wheel odometry. This information will come from AGCBox in Raw format to be used in an Kalman filter to provide the final pose of the vehicle.

##### *Environment Perception*

For tractor localization and navigation in the farming environment, state-of-the-art-alike SLAM/navigation algorithms will be implemented. For the environment perception the potential sensor configuration would be, one 3D lidar along with an RGBD camera in the front of the tractor and one RGBD camera in each side of the tractor to avoid blind spots. The 3D lidar can also be used to build 3D reconstructions of the working area from point clouds.

##### *Safety*

Agricultural work is one of the most dangerous jobs nowadays. But autonomous machinery is making the industry safer by taking on some of the hard labour and putting distance between workers and dangerous equipment. Inclusion of an emergency stop function, or e-stop function, has been a machine standard for years. According to ISO 13850:2015, machine e-stop function "is intended to avert arising or reduce existing hazards to persons, damage to machinery or to work in progress, and be initiated by a single human action".

#### **E-stop button**

Traditionally, e-stop buttons are placed on the machine. But in emergency situations, this means a person would be running towards danger to stop it instead of away from it. Integrating a wireless e-stop allows farmers to stop the machine (autonomous mobile robot) immediately from a distance if abnormal or unsafe behaviour is observed. The ability to wirelessly stop the robot keeps humans out of the danger zone. An e-stop will be included for safety on board the retrofitted tractor and the usage of a wireless e-stop button will be analysed in order to increase the safety conditions for the project. This wireless e-stop button could be either included via an industrial-grade remote controller or as a standalone device.



*Figure 14. Left, Wired e-stop. Centre, remote industrial-grade remote controller. Right, wireless e-stop.*

---

<sup>4</sup> This section is future plan because the retrofitting works will start at January 2022, when the tractor will be delivered to AGC, responsible of the retrofitting works.

### D3.1 Autonomous capabilities definition

#### Pressure-sensitive bumpers

Pressure-sensitive bumpers are instrumented to trigger a safety rated stop if they collide with an obstacle. Bumper activation shall cause a safety stop within the collapsible range of the bumper and before the vehicle strikes an obstacle. The only way to avoid injury is for contact to happen at very low speeds. For this reason, bumpers are located on portions of the autonomous device that might contact something at very low speeds, typically lower than 0.3 m/s (18 m/min).

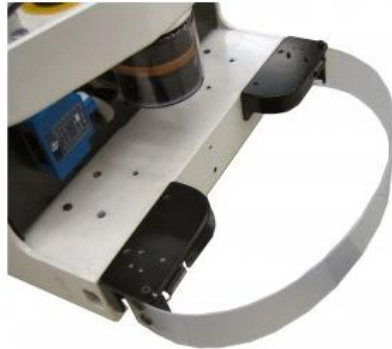

*Figure 15. Pressure-sensitive bumper.*

#### Safety laser scanners

A safety laser scanner scans its surrounding-2D-near environment using infrared laser beams to detect if an obstacle enters inside a pre-configured protective field. As soon as an object appears in the protective field, the safety laser scanner signals the detection. One potential candidate for this role is Sick LMS511 laser scanner. This laser is a robust, accurate, high-speed device for outdoor robotic applications.



*Figure 16. Sick LMS511 for outdoor safety applications.*

#### Localization

In order to increase the robustness and accuracy of the localization task, the RTK position will be fused into a SLAM<sup>5</sup> algorithm, so the tractor can still be localized even when the RTK/GNSS service is not available, due to lack of satellite visibility. The SLAM paradigm is graph-based, which means that a frontend component builds a graph by adding nodes and edges based on motion estimations, while the backend process performs optimization of

---

<sup>5</sup> Simultaneous Localization and Mapping

### D3.1 Autonomous capabilities definition

this graph minimizing the error. The system must be capable of closing loops by matching visual or range information from non-consecutive measurements.

The following inputs are needed for running the SLAM system:

- Robot odometry.
- Estimated RTK location from the GNSS module.
- Laser scans from the 3D LIDAR.
- IMU measurements.
- Depth camera data.

As a result, the module should output a 3D map in a memory-efficient format such as, OcTree, and the robot pose at a minimum rate of 1Hz. All sensors described in previous sections are focused on performing a very robust SLAM method for localization.

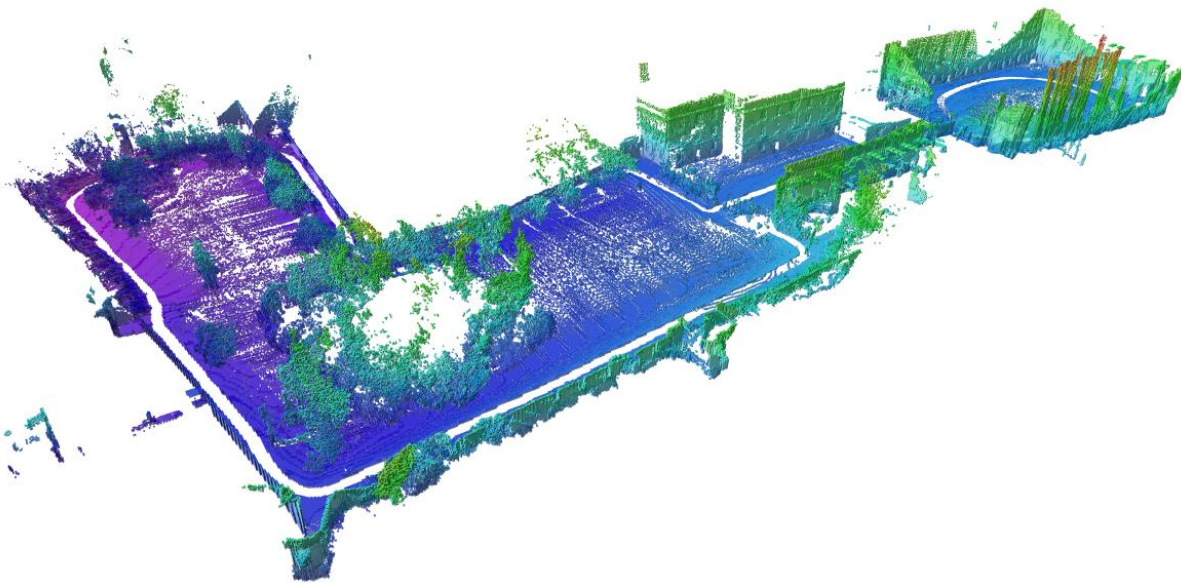

*Figure 17. Octree representation of a map.*

### Navigation

Autonomous vehicles, like the retrofitted tractor in this project, base their decisions on planner modules that create the collision-free waypoints in the path to reach the destination point. These modules can find the optimal solution minimizing the computational time and distance covered by the vehicle avoiding static and dynamic obstacles. Traditionally, the navigation module is divided into a global planner and a local planner, where the first one finds the optimal path with a prior knowledge of the environment and static obstacles (for example a map of the environment), and the second one recalculates the path to avoid dynamic obstacles.

For the tractor, different planners will be tested to decide which methods have the best behaviour in the LSP, from the point of view of robustness, safety and productivity.

## Chapter 3 Large Scale Pilot definition and constraints

There are four LSP in this project: In France, Greece, Spain and Netherlands. Each one is conceived to demonstrate the feasibility and reliability of applying robotics in agriculture. The autonomous vehicles will be used in these LSP according to its characteristics and the type of crop to work with.

### France: Mechanical weeding in Vineyards

Mechanical weeding in vineyards with a tractor driver is not economically attractive (€800 per ha; 5-7 passes per year). Moreover, around seven different implements are used to achieve complete crop management: 3 tools for inter-row and 4 tools for intra-row, with 3 experienced drivers to handle the tractor/implement operation for an area of 40 ha. The goal is to deploy and test the **Ceol robot**, since it is currently used for 3 passes per season and €250 per ha in Loire Valley. In this pilot, all possible implement configurations on the Ceol robot will be used, in order to reduce chemicals used and labor costs and to evaluate the modularity of the platform on different implements and working scenarios.

Localization	Loire Valley, France
Type of crop	Vineyard
Type of soil	Sand / Pebbles / Clay
Distance between rows	2 meters
Plant height	0.4 – 0.7 meters
Slope	Plain
Possible obstacles (electric towers, poles....)	Poles, high weeds
Covering materials (nets, cables....)	No

*Table 5. Characteristics for the vineyard large scale pilot in France.*

#### Main challenges with reference to autonomous vehicles

- Enough position accuracy to not confuse the working row.
- Strict path planning.
- Relatively high working speed.

### France: Mechanical weeding in vegetables

Traditional vegetable farms in the Loire Valley are based on bed cropping, in open field or under cold plastic greenhouse. More than 60 kinds of vegetables are grown, and the pilot area requires 20 workers for an area of 70 ha to cultivate salads, lamb lettuce, leeks, baby-leaf salad, carrots, and in one year, several (3-5) crops are produced at the same place. As a result, many kinds of tasks must be managed on different vegetables, and many tools must be available at any time, while several passes of tractors damage the soil and cause severe compaction. That is the reason why, most often, old tractors are used with always the same tool: tools are not uncoupled. Thus, the testing site will be established to focus on high precision inter- and intra-row weeding of vegetables using the **Ceol robot** and several different mechanical weeding implements attached. Emphasis will be given on navigation and weeding along the rows, in order to ensure that Ceol does not drive over the plants and that the weeding knives make accurate distinction between vegetables and weeds.

### D3.1 Autonomous capabilities definition

Localization	Loire Valley, France
Type of crop	Lettuce
Type of soil	Sand
Distance between rows	2 meters
Plant height	1 meter
Slope	Plain
Possible obstacles (electric towers, poles...)	No
Covering materials (nets, cables...)	Plastic cover with metallic structure.

*Table 6. Characteristics for the vegetable large scale pilot in France.*

#### Main challenges with reference to autonomous vehicles

- High position accuracy to not damage the vegetables.
- Relatively slow working speed.
- Covers may cause GNSS interferences.

### Greece: Spraying in table grapes

The Greek pilot will focus on spraying table grape vineyards. Table grapes is an important product in the Mediterranean basin and indeed, the EU is the third larger producer of table grapes in the world after China and Turkey. Getting the quality level needed is not an easy task for table grape growers, since the crop has a short shelf life, supermarkets and consumers impose very high-quality standards quality standards and the fruit is highly sensitive to pests and diseases, with preventive and curative spraying to occupy most of the farmer's effort throughout the season. As a result, table grapes need up to 30 applications of pesticide and foliar fertilizer each growing season. Labour costs are high and access to workforce is difficult (ten experienced workers for spraying in PEG), especially when considering the limited time window available for the spraying applications. So, ROBS4CROPS addresses those challenges by deploying the Ceol robot and an autonomous tractor as carrying platforms of the lift-mounted ASM model sprayer from Teyme (600L tank capacity).

Localization	Vocha, Greece
Type of crop	Table grapes
Type of soil	Clay
Distance between rows	2.7 meters
Plant height	1.8-2 meters
Slope	Plain
Possible obstacles (electric towers, poles...)	Poles
Covering materials (nets, cables...)	Protective nets supported by metallic structures

*Table 7. Characteristics for the large scale pilot in Greece.*

#### Main challenges with reference to autonomous vehicles

- Enough position accuracy to not confuse the working row.
- Strict path planning.

### D3.1 Autonomous capabilities definition

- Relatively high working speed.
- Covers may cause GNSS interferences.
- U-turns with a pulled sprayer (Tractor) could be problematic.

## Spain: Spraying in apple orchards

One of the most popular fruits cultivated in the Catalonia region are apples with the Giropoma Costa Brava S.I. cooperative producing in an area of 140 ha a total yield of 30-35,000 tonnes per year, with a value of around 30 million euros. However, apple orchards require many spray applications to be protected against fungal diseases. As a result, a large amount of fungicides is used and much labour is needed for their application, while farmers do not consider the growing stage of the trees and the disease severity when applying chemicals (uniform application). This project will address the labour challenge that apple sector is currently facing while reducing the amount of chemicals used, by automating the complex task of orchard spraying. This will be achieved by deploying an **autonomous tractor** and a pulled sprayer of Teyme (EOLO model), a smart trailed mist-blower of 2000L tank capacity and precision spraying capabilities.

Localization	Girona, Spain
Type of crop	Intensive apple crops
Type of soil	Loam-silty
Distance between rows	3.8 meters
Plant height	4 meters
Slope	Plain
Possible obstacles (electric towers, poles...)	Inclined structure poles and irrigation shed in the middle of the plot
Covering materials (nets, cables...)	Nets and its supportive structure (transversal cables)

*Table 8. Characteristics for the large scale pilot in apple orchards in Spain.*

### Main challenges with reference to autonomous vehicles

- Enough position accuracy to not confuse the working row.
- Strict path planning.
- Relatively high working speed.
- Covers may cause GNSS interferences.
- U-turns with a pulled sprayer (Tractor) could be problematic.

## The Netherlands: Weeding in potato-based crop rotation

In the Netherlands, the project will establish a pilot in a potato-based crop rotation. Netherlands is the 4th largest producer of potatoes and seed potatoes in EU, with more than 6 million tonnes each year. In this pilot, the **Robotti robot** will be used in a farm where the potato area is up to 50 ha. Presently, heavy conventional tractors are used in combination with various implements to perform most of the field operations which leads to soil structure damage. The robot used weighs 1/3 of the traditional machinery and can be used to perform several operations including early seeding of the main crop, mechanical weeding, hilling, harvest potato with single-row harvester while minimising damage to the

### D3.1 Autonomous capabilities definition

soil structure. An additional benefit due to the small size of the robot is that can perform mechanical weeding in two directions. The pilot will use the Robotti robot and a smart weeder. The camera-based weeder will be used to weed in pumpkins in the crop rotation.

Localization	Thesinge, Nederland
Type of crop	Potatoes
Type of soil	Clay
Distance between rows	0.75 meters
Plant height	0.3 metres
Slope	Plain
Possible obstacles (electric towers, poles....)	No
Covering materials (nets, cables....)	No

*Table 9. Characteristics for the large scale pilot in potatoes in Nederland.*

#### Main challenges with reference to autonomous vehicles

- High position accuracy to not damage the vegetables.
- Relatively slow working speed.



## Chapter 4 Large-scale pilots' Autonomous capabilities definition

In this section the most important autonomous capabilities are defined with reference to the LSP requirements. The capabilities explained are the ones needed for a robust and feasible autonomous behaviour, taking into account the characteristics of each LSP (terrain, soil, slope...) and the work to be done by each vehicle.

Each capability has been related with one or more metrics defined in Deliverable 1.4 (Sec. 3.3) that will be used to quantify performance during the tests.

### CEOL (Weeding in France, in Greece)

#### Straight-line navigation

(MET\_TEC\_UGV\_02)

Using the Fixed base and the AGC Box, Ceol has +/-2cm accuracy with GNSS-RTK

#### Way-point routing

(MET\_TEC\_UGV\_02)

Way points (the mission) is downloaded using the Application.

#### Mission planning

(MET\_TEC\_UGV\_17) (MET\_TEC\_UGV\_18) (MET\_TEC\_UGV\_19) (MET\_TEC\_UGV\_22) (MET\_TEC\_UGV\_23)  
(MET\_TEC\_UGV\_24)

The mission planner is a web interface for mission generation and simulation. IA Mission is the working path defined for a robot/implement combination on a plot. Used for:

Generation of the route for CEOL

Mission optimization

Validation test on simulator

#### Effective turns to change plant lines. (U-Turns, Zero-turns)

(MET\_TEC\_UGV\_14)

The robot optimizes its path and choses the U-turns accordingly:

Type of U-turns:



Figure 18. Three-point for the CEOL robot.

## D3.1 Autonomous capabilities definition



Figure 19. Bulb U-turn for the CEOL robot.

### Obstacle detection

(MET\_TEC\_UGV\_03)

The robot is equipped with a Lidar for obstacle detection it reduces its speed and stops.

In the future the cameras and the teleoperation will be integrated for obstacle detection.

### Obstacle avoidance

(MET\_TEC\_UGV\_03)

The obstacle avoidance is implemented through the SafeFencing algorithms.

In vineyards, the narrow lanes between two rows of vines make it impossible to navigate around an obstacle. Instead, the robot can skip a lane if an obstacle blocks its way.

### Safety stop

(MET\_TEC\_UGV\_03)

An emergency stop is situated on the sides and the top of the robot. The safety edge (bumper) stops immediately the robot, and it has to be restarted by the operator next to the operator for safety reasons

### Failure detection and recovery (Localization failure, non-avoidable obstacle, electrical failure, hydraulic failure, can't reach a goal...)

(MET\_TEC\_UGV\_08) (MET\_TEC\_UGV\_09)

For the localization the robotic system is equipped with an IMU, a GNSS receptor and a fixed base for receiving the position every 200ms. In case of system failure, the robot stops and sends a light signal on the AGC Box, in the future it will be able to send an SMS.

For most of the failures a light indication on the AGC Box explains to the operator the type of failure. In the near future the operator will be able to receive a SMS for most of the problems encountered by the robot. Any electrical failure leads to the instant stop of the robot until the operator restarts the robot.

If the robot can't reach a goal, it will change the path that has been previously defined without crossing the perimeter defined at the land survey and due to the algorithms of SafeFencing.

## D3.1 Autonomous capabilities definition

### Meteorology robustness (wind, rain capacities....)

*(MET\_TEC\_UGV\_05) (MET\_TEC\_UGV\_10) (MET\_TEC\_UGV\_11) (MET\_TEC\_UGV\_16)*

The robot can work in wind conditions and after the rain, only if the soil is very slippery. The robot can work where a tractor can work. Most of the components are IP65 but the robot cannot work under heavy rain.

### Operation in non-easy terrains (slope, slippery soil, wet soil, mud....)

*(MET\_TEC\_UGV\_13) (MET\_TEC\_UGV\_15)*

CEOL can work in light slopes depending on the implement (its weight and if it is tracked or mounted). The robot is on tracks and can work in any type of soil the speed is reduced according to the type of soil. In the future the robot will be able to work in slippery soil.

### Nets covering the orchards. (Lack of GNSS/GSM signal)

The GNSS signal is often lost or very low with a high interference level in orchards covered by nets. The nets must be folded for the robot's work.

## ROBOTTI (weeding in Netherlands)

### Straight-line navigation

*(MET\_TEC\_UGV\_02)*

+/- 2 cm accuracy (RTK GPS).

### Way-point routing

*(MET\_TEC\_UGV\_02)*

Way points are downloaded using the mobile connection.

### Mission planning

*(MET\_TEC\_UGV\_17) (MET\_TEC\_UGV\_18) (MET\_TEC\_UGV\_19) (MET\_TEC\_UGV\_22) (MET\_TEC\_UGV\_23) (MET\_TEC\_UGV\_24)*

The farmer is able to highly customize their plans. They can input implement information, field boundaries (import shape file, drive with robot, or draw), headline size, row or bed sizes, transit areas, how to turn, how to turn on corners, AB lines, optimized path, etc.

### Effective turns to change plant lines. (U-Turns, Zero-turns)

*(MET\_TEC\_UGV\_14)*

Robotti can perform a zero turn to reduce the area in which the robot needs to turn. Robotti can also skip a row and perform a normal turn. Because of safety reasons, Robotti cannot drive backwards, so it cannot perform a 3-point turn.

### Obstacle detection

*(MET\_TEC\_UGV\_03)*

The 3D laser can currently detect if there is an obstacle in front of the robot.

In the future, it is expected that AGI will have DL algorithms that can detect the obstacle using the front and rear cameras.

### Obstacle avoidance

*(MET\_TEC\_UGV\_03)*

Yes, the robot is able to stop if it detects an obstacle using the lidar.

AGI does not plan on driving around the obstacle, as it would be necessary to drive on the farmer's crop.

## D3.1 Autonomous capabilities definition

### Safety stop

(MET\_TEC\_UGV\_03)

The bumper is the official safety system as seen from a CE marking perspective. Additional safety elements are below:

Pressure sensitive bumper	Standard
Emergency stop buttons	Standard
GNSS-based virtual fencing	Standard
Remote controller /joystick standard	Standard
Laser scanner	Standard
Vision computer and camera package (front and rear)	Optional
Light package (front and rear)	Optional

*Table 10. Safety and navigation characteristics of the Robotti platform.*

The robot's safety system surrounds the front and sides of the implement, therefore it is not required to have a safety system on the implement.

### Failure detection and recovery (Localization failure, non-avoidable obstacle, electrical failure, hydraulic failure, can't reach a goal...)

(MET\_TEC\_UGV\_08) (MET\_TEC\_UGV\_09)

When there is a failure, the error message is displayed in the Robotti Web Services portal. AGI is also able to monitor these failures to be able to react faster to repairing the problem for the farmer. The farmer is also able to see the status and how much the operation has been completed.

When the robot is at 15% full tank, a SMS is sent to the farmer, warning the fuel levels are low. When the operation is completed, the farmer will receive a SMS with the robot asking to be picked up and the operational information.

If there is a non-avoidable obstacle, the robot will stop, and an error message will be displayed. The farmer needs to decide at this point, as we are not allowed to drive on the farmer's crop.

### Meteorology robustness (wind, rain capacities....)

(MET\_TEC\_UGV\_05) (MET\_TEC\_UGV\_10) (MET\_TEC\_UGV\_11) (MET\_TEC\_UGV\_16)

Robotti is IP67, therefore theoretically the robot can operate in any conditions. Agronomically, it is advisable not to operate the robot in heavy rainfall and there are certain operations where it is advisable not to operate the robot when raining.

### Operation in non-easy terrains (slope, slippery soil, wet soil, mud...)

(MET\_TEC\_UGV\_13) (MET\_TEC\_UGV\_15)

Robotti can work in most conditions, however there is a limit. The robot can handle some slope, slippery soil, wet soil, mud, etc. The heavier the implement is, the more likely the robot will have problems with difficult conditions.

### Nets covering the orchards. (Lack of GNSS/GSM signal)

No, but in the future the robot will be able to navigate based on plant rows.

# Retrofitted tractor (spraying in Spain and Greece)

## Straight-line navigation

*(MET\_TEC\_UGV\_02)*

The straight line navigation accuracy is within the typical range of the RTK GNSS technique, which is +/- 2 cm accuracy.

## Way-point routing

*(MET\_TEC\_UGV\_02)*

Way points defining a global path between the vehicle's pose and the target pose, in order to achieve a task, are provided by the Farming Controller, developed by the partner LMS. This global path is transmitted within a ROS network, where the EUT and LMS nodes run, using the publisher/subscriber paradigm, which relies in a customized transport control protocol, called ROS TCP under the hood, so any kind of physical connection can be used for this connection, either by wire (RJ45 cable, etc.) or wireless (WiFi, 4G mobile band), as long as there is a network connection between the ROS nodes.

## Mission planning

*(MET\_TEC\_UGV\_17) (MET\_TEC\_UGV\_18) (MET\_TEC\_UGV\_19) (MET\_TEC\_UGV\_22) (MET\_TEC\_UGV\_23) (MET\_TEC\_UGV\_24)*

The mission will be computed by the Farming Controller which will generate an efficient route taking into account different aspects of the field. The tractor will follow this route in a way-point list structure.

## Effective turns to change plant lines. (U-Turns, Zero-turns)

*(MET\_TEC\_UGV\_14)*

Due to the large variation of field shapes and sizes, the maneuverability of a field machine is important, with turning radius being the most important parameter.

The turning radius is a measure of how easy the tractor will either perform a U-turn or park. The term turning radius refers to the minimum radius a vehicle will use to turn with the steering wheel positioned to the full lock position. The turning circle is usually measured in meters using the front outside tire.

The turning radius has a great impact on field efficiency. The larger the turning radius, the more space the machine will need to turn around. That is, more time will be spent on turning. A smaller turning radius will allow less turning time and smaller headland space to turn the machine around.

The tractor purchased in the Robs4Crops project from the manufacturer New Holland is equipped with an innovative proprietary technology, called SuperSteer, where the front axle turn up to 76 degrees, providing a turning radius as low as 2.980 meters for truly outstanding agility. The way in which the axle moves as the steering lock is increased helps to reduce front wheel scrub. With sharper and faster turning, maneuvering in tight spaces and small fields is easy. Headland turn time is reduced, providing a huge advantage for row-crop operations.

An important characteristic for the LSP, mostly the Spanish pilot, will be the ability of making U-Turns pulling an implement. Particularly, for this pilot, the tractor will pull an approximate 3-meter sprayer. This configuration and its behaviour in the turns must be taken into account.

### D3.1 Autonomous capabilities definition



Figure 20. Turning radius for the retrofitted tractor T4.F100.

Caption: Turning radius for the tractor model New Holland T4.F100 equipped with the technology SuperSteer.

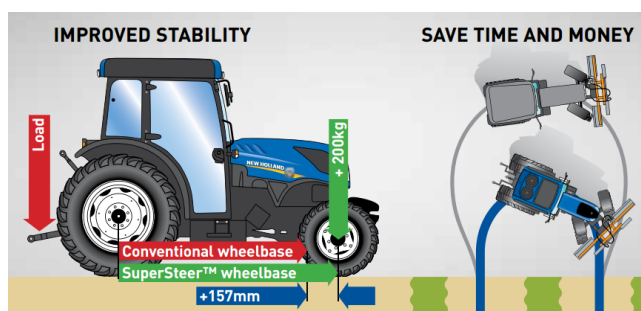

Figure 21. Example of sharper turning radius when performing a trajectory due to the SuperSteer technology from New Holland.

### Obstacle detection

(MET\_TEC\_UGV\_03)

A 3D scan laser mounted in the front section of the tractor, looking forward, is used for localization, navigation and obstacle detection.

In addition to the 3D laser there is also the need to add depth cameras to the system so computer vision techniques can be used in order to determine if an obstacle is relevant or on the other hand the tractor can drive safely. Small obstacles such as small tree branches will cause the tractor to stop if only a laser scanner is used. If in addition a computer vision algorithm is used, it may be determined that the tractor can continue safely on its path despite the presence of a small tree branch.

### Obstacle avoidance

(MET\_TEC\_UGV\_03)

If an obstacle is detected in the area around the robot at a distance less than some warning threshold, the robot must stop. When working in farming environments it is almost impossible to avoid an obstacle, because most of the times this action will require the robot to drive on the farmer's crop, which obviously is not an option, or simply there is no free space to avoid the obstacle. The main challenge, in general in all LSP, is to have a robust obstacle avoidance in headlands during the turns, where effectively can be where is more probable to have an avoidable obstacle (poles, rocks, fruit boxes...) This is even more difficult in the case of tractor, pulling the sprayer and having a non-rigid system. In this case, an specific headland obstacle avoidance protocol will be implemented for the tractor to face this challenge.

## D3.1 Autonomous capabilities definition

### Safety stop

(MET\_TEC\_UGV\_03)

As mentioned in the previous paragraph, any time an obstacle appears in the warning zone around the tractor, it must stop immediately. In addition to the laser safety stop, the tractor must be equipped with a safety bumper in order to be compliant with the CE marking. Finally a couple of emergency stop buttons will be deployed in the tractor itself for robustness and redundancy.

The robot's safety system surrounds the front and sides of the implement, therefore it is not required to have a safety system on the implement.

### Failure detection and recovery (Localization failure, non-avoidable obstacle, electrical failure, hydraulic failure, can't reach a goal...)

(MET\_TEC\_UGV\_08) (MET\_TEC\_UGV\_09)

When there is a failure, first the robot stops and secondly it sends an error message to the Farming Controller.

### Meteorology robustness (wind, rain capacities...)

(MET\_TEC\_UGV\_05) (MET\_TEC\_UGV\_10) (MET\_TEC\_UGV\_11) (MET\_TEC\_UGV\_16)

The New Holland T4.F100 tractor is IP67, therefore it can operate in any environmental/weather conditions.

### Operation in non-easy terrains (slope, slippery soil, wet soil, mud...)

(MET\_TEC\_UGV\_13) (MET\_TEC\_UGV\_15)

The New Holland T4.F100 tractor is equipped with an 4WD advanced traction management that engages drive to the front wheels if rear wheel slip exceeds 5% and on slopes of steeper than 10 degrees. For stability and safety, 4WD is also engaged when both brake pedal are pressed. The front and rear differentials are engaged and released by a dash mounted switch.

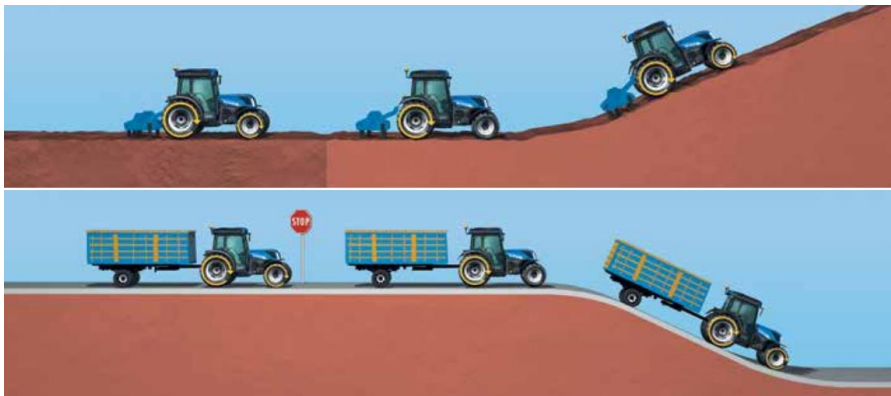

*Figure 22. New Holland T4.F100 tractor navigating in different environments with diverse load conditions and presenting distinct slopes.*

### Nets covering the orchards (lack of GNSS/GSM signal)

The tractor must be able to navigate not only when there are GNSS signals available but also when this system is denied based on the architectural elements placed in the environment. To achieve that behavior an advanced simultaneous localization and mapping algorithm (SLAM), using the GNSS signals as well as the laser scans, depth camera images and odometers, will be used to command the navigation of the tractor.